

## IF IT'S NOT ON THE LIST, IT'S COVERED! (It even includes rental up to 6 days.)

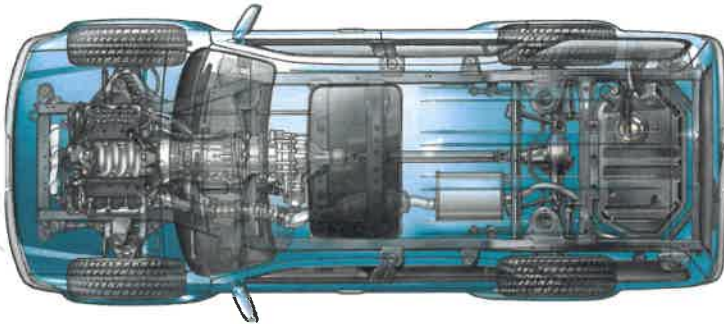

Premier covers everything in all of the other plans – and more. In fact, it's so comprehensive that this "exclusionary" contract lists only the things not covered. In other words, if it's not listed on the contract, IT IS COVERED!

Your Premier Plan covers practically all factory-installed mechanical and electrical operating parts. The few items not covered are typically those involved in scheduled services and normal wear and tear, such as\*:

- Regular maintenance services as recommended by the manufacturer
- Normal maintenance parts and services such as engine tune-ups, batteries, filters, fluids, A/C refrigerant, hoses and belts, wiper blades, brake pads, tires, wheels and balancing, exhaust system, catalytic converter and manual clutch components
- Window glass, head lamps, trim, moldings, upholstery, convertible tops, paint, sheet metal & flexible body parts, bumpers, door panels & handles and structural framework
- Aftermarket accessories or equipment not installed by the manufacturer
- Repairs to meet emissions standards
- Hybrid vehicle battery

\*Listed items are general guidelines only. Please see contract for complete details. A form of contract can be obtained by contacting your dealer or a PWI representative.

## NEAR OR FAR, WE'VE GOT YOU COVERED.

Your Premier Plan also offers **Trip Inconvenience coverage** that could reimburse you up to \$100 a day for meals and lodging for up to three (3) days if disaster strikes when you're more than 100 miles from home.\*\*

\*\*Please see contract for complete Trip Inconvenience coverage details.

*At the Administrator's election, repair or replacement of COVERED PARTS will be made with parts of like kind and quality, including but not limited to new, re-manufactured, exchanged, or used components.*

*In Florida, contracts are administered by American Auto Shield, Inc. (Florida Company Code 14044), 1597 Cole Blvd., Suite 200, Lakewood, CO 80401. In Washington and Alaska, contracts are administered by American Auto Shield, LLC.*

*In Washington and Alaska, the obligor and provider is American Auto Shield, LLC. In Florida, the obligor and provider is American Auto Shield, Inc. (Florida Company Code 14044).*

**DRIVE WITH CONFIDENCE, COAST-TO-COAST.™**